

# WALLBOX

## ICEBOX

## WORKSTATION COCKTAIL

STILTEK

# STILTEK

an **arneg** company

Stiltek, assieme ai marchi Frigomeccanica, Officine 900 e Frimar, è oggi parte del Gruppo Arneg. Con oltre 50 anni di storia, rappresenta un'eccellenza tutta italiana, sinonimo di qualità, affidabilità e innovazione nei mercati nazionali e internazionali.

Stiltek è un reparto attrezzato di macchinari di ultima generazione per la lavorazione dei metalli ed ha per oggetto specifico la produzione di un'ampia gamma di moduli refrigerati e neutri quali componenti tecnologici per l'arredamento di attività commerciali (bar, gelaterie, pasticcerie). La produzione Stiltek, realizzata interamente con tubolari di alluminio e lamiere di acciaio inox, è molto flessibile, ben si adatta ad ogni esigenza ed è garanzia di assoluta durata nel tempo. I moduli Stiltek sono la soluzione ideale per quanti progettano e realizzano arredi per pubblici esercizi ed intendono concretizzare le loro idee completando i moduli Stiltek con pannellature e finiture di ogni genere. L'ingresso nel Gruppo Arneg ha permesso a Stiltek di consolidare la propria visione strategica, valorizzando competenze condivise, sinergie operative e know-how industriale per rafforzare ulteriormente la propria presenza nel mondo.

EN

Stiltek, along with the Frigomeccanica, Officine 900, and Frimar brands, is now part of the Arneg Group. With over 50 years of history, it represents Italian excellence, synonymous with quality, reliability, and innovation in national and international markets.

Stiltek is a department equipped with latest-generation machinery for metalworking and specifically focuses on the production of a wide range of refrigerated and ambient modules as technological components for commercial furnishing (bars, ice cream parlors, pastry shops). Stiltek production, made entirely with aluminum tubing and stainless steel sheets, is highly flexible, adapts well to every need, and guarantees absolute durability over time. Stiltek modules are the ideal solution for those who design and create furnishings for public venues and wish to bring their ideas to life by completing Stiltek modules with all kinds of paneling and finishes.

Joining the Arneg Group has allowed Stiltek to consolidate its strategic vision, leveraging shared expertise, operational synergies, and industrial know-how to further strengthen its global presence.

FR

Stiltek, avec les marques Frigomeccanica, Officine 900 et Frimar, fait aujourd'hui partie du Groupe Arneg. Avec plus de 50 ans d'histoire, elle représente une excellence entièrement italienne, synonyme de qualité, de fiabilité et d'innovation sur les marchés nationaux et internationaux.

Stiltek est un département équipé de machines de dernière génération pour le travail des métaux et a pour objet spécifique la production d'une large gamme de modules réfrigérés et neutres en tant que composants technologiques pour l'aménagement d'activités commerciales (bars, glaciers, pâtisseries). La production Stiltek, entièrement réalisée avec des tubes en aluminium et des tôles en acier inoxydable, est très flexible, s'adapte parfaitement à chaque exigence et garantit une durabilité absolue dans le temps. Les modules Stiltek sont la solution idéale pour ceux qui conçoivent et réalisent des aménagements pour les établissements publics et souhaitent concrétiser leurs idées en complétant les modules Stiltek par des habillages et des finitions de toutes sortes.

L'intégration au sein du Groupe Arneg a permis à Stiltek de consolider sa vision stratégique, en valorisant les compétences partagées, les synergies opérationnelles et le savoir-faire industriel pour renforcer davantage sa présence dans le monde.



DE

Stiltek gehört heute zusammen mit den Marken Frigomeccanica, Officine 900 und Frimar zur Arneg-Gruppe. Mit einer über 50-jährigen Geschichte steht das Unternehmen für italienische Exzellenz, die auf nationalen und internationalen Märkten als Synonym für Qualität, Zuverlässigkeit und Innovation gilt. Stiltek ist eine mit modernsten Maschinen zur Metallverarbeitung ausgestattete Abteilung, deren Schwerpunkt auf der Herstellung einer breiten Palette von gekühlten und ungekühlten Modulen als technologische Komponenten für die Einrichtung von Gewerbebetrieben (Bars, Eisdielen, Konditoreien) liegt. Die vollständig aus Aluminiumrohren und Edelstahlblechen gefertigte Produktion von Stiltek ist sehr flexibel, passt sich jedem Bedarf an und garantiert absolute Langlebigkeit. Die Module von Stiltek sind die ideale Lösung für Planer und Hersteller von Einrichtungen für öffentliche Lokale, die ihre Ideen durch die Ergänzung der Stiltek-Module mit Verkleidungen und Oberflächen jeglicher Art verwirklichen wollen. Der Eintritt in die Arneg-Gruppe hat es Stiltek ermöglicht, seine strategische Vision zu festigen und gemeinsame Kompetenzen, operative Synergien sowie industrielles Know-how zu nutzen, um seine weltweite Präsenz weiter zu stärken.

ES

Stiltek, junto con las marcas Frigomeccanica, Officine 900 y Frimar, forma parte hoy del Grupo Arneg. Con más de 50 años de historia, representa una excelencia totalmente italiana, sinónimo de calidad, fiabilidad e innovación en los mercados nacionales e internacionales.

Stiltek es un departamento equipado con maquinaria de última generación para la transformación de metales y tiene como objeto específico la producción de una amplia gama de módulos refrigerados y neutros como componentes tecnológicos para el mobiliario de actividades comerciales (bares, heladerías, pastelerías). La producción de Stiltek, realizada íntegramente con tubulares de aluminio y chapas de acero inoxidable, es muy flexible, se adapta bien a cada necesidad y es garantía de absoluta durabilidad en el tiempo. Los módulos Stiltek son la solución ideal para quienes proyectan y realizan mobiliario para establecimientos públicos y desean concretar sus ideas completando los módulos Stiltek con paneles y acabados de todo tipo.

La entrada en el Grupo Arneg ha permitido a Stiltek consolidar su visión estratégica, poniendo en valor las competencias compartidas, las sinergias operativas y el know-how industrial para reforzar aún más su presencia en el mundo.

# WALLBOX

WALLBOX È UNA LINEA DI MOBILI PENSILI REFRIGERATI STUDIATI APPOSITAMENTE PER L'ESPOSIZIONE E LA PERFETTA REFRIGERAZIONE DI BEVANDE, PASTICCERIA E GASTRONOMIA FREDDA. LA CURA DEI PARTICOLARI, L'ALTA QUALITÀ DEI MATERIALI E LA TECNOLOGIA UTILIZZATA RENDONO WALLBOX PRODOTTO DI RIFERIMENTO NEL SUO GENERE.

WALLBOX IS A RANGE OF REFRIGERATED CABINETS DESIGNED SPECIFICALLY FOR DISPLAY AND PERFECT REFRIGERATION OF BEVERAGES, CONFECTIONERY AND DELICATESSEN FOODS. THE FOCUS ON DETAILS, THE HIGH QUALITY OF THE MATERIALS AND THE TECHNOLOGY USED MAKE WALLBOX THE REFERENCE PRODUCT IN ITS GENRE.









# WALLBOX

STILTEK



# WALLBOX

STILTEK





I PENSILI WALLBOX AD ALTE  
PERFORMANCE TECNOLOGICHE  
SONO UN PRODOTTO  
SQUISITAMENTE ITALIANO. NASCONO  
PER L'ESPOSIZIONE A INCASSO, A  
PARETE, E PER IL RETROBANCO.

THE HIGH-TECHNOLOGY WALLBOX CABINETS  
ARE AN EXQUISITELY ITALIAN PRODUCT.  
THEY ARE DESIGNED FOR RECESSED WALL  
AND BEHIND-THE-COUNTER DISPLAY.



# WALLBOX



# STILTEK

## WALLBOX NERO BLACK



**IT\_** Mobile pensile refrigerato per alimenti e bevande con impianto refrigerante ventilato a valvola termostatica, struttura in acciaio rivestito per alimenti e poliuretano iniettato isolante alla densità di 38/40 kg/mc, fondo interno con bordi raggiati e scarico condensa, sportelli in vetrocamera, illuminazione con plafoniere a LED, mensola intermedia in vetro temperato regolabile in altezza, griglie di fondo in acciaio inox, quadro di comando elettronico programmabile, fissaggio a parete con apposita staffa.  
Temperatura di esercizio +2°+7°C

**EN\_** Refrigerated cabinet for food and beverage products with a thermostatic valve ventilated refrigeration system, coated steel structure for foods and 38/40 kg/m<sup>3</sup> injected polyurethane insulation, interior bottom with smooth edges and condensation plughole, double-glazed glass doors, LED ceiling lighting, tempered glass intermediate shelf adjustable in height, stainless steel bottom grills, programmable electronic control panel, wall-mounted with special brackets.  
Operating temperature +2°+7°C

**COLORI STRUTTURA:**  
**STRUCTURE COLOURS:**

-  sportello nero  
black door
-  interno/esterno  
acciaio colore nero  
interior/exterior  
stainless steel black

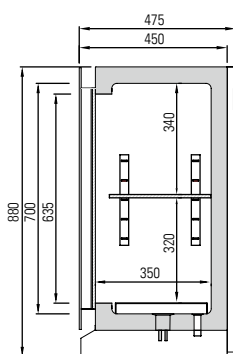

capacità pensile LT 196  
cabinet capacity 196 litres

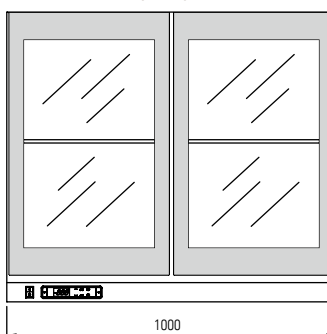

capacità pensile LT 318  
cabinet capacity 318 litres

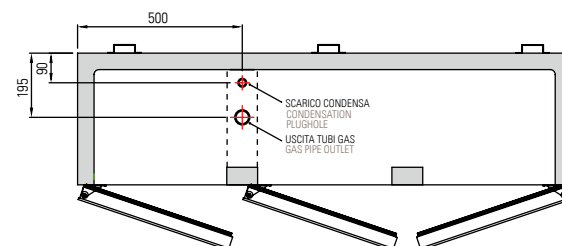
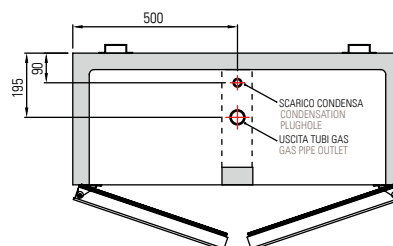
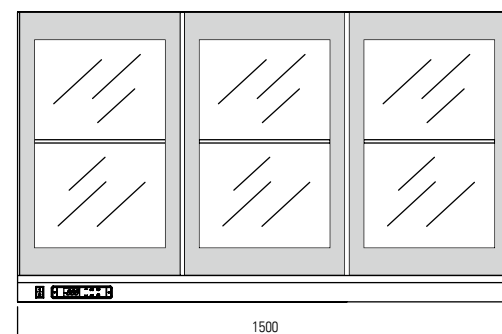

# WALLBOX

STILTEK





LE PORTE DI WALLBOX SONO IN VETRO CON SERIGRAFIA DI COLORE NERO O BIANCO E POSSONO AVERE APERTURA VERSO DESTRA O VERSO SINISTRA. L'ILLUMINAZIONE INTERNA A LED È CON TEMPERATURA DI COLORE 4.000° K, MA SU RICHIESTA È DISPONIBILE ANCHE LA VERSIONE 3.000° K.

WALLBOX doors are made of glass with black or white silk-screen printing and can be opened to the right or to the left. The internal LED lighting has a color temperature of 4,000 K, but a 3,000 K version is also available upon request.

# WALLBOX

STILTEK





# WALLBOX

STILTEK





# WALLBOX

I PENSILI SONO OTTIMI PER LA CONSERVAZIONE NON SOLO DELLE BIBITE MA ANCHE DELLE PIETANZE. SALUMERIA, GASTRONOMIA FREDDA E ANCHE PASTICCERIA TROVANO IN QUESTI PENSILI LA CONSERVAZIONE IDEALE. GLI SPORTELLI SONO IN VETRO TEMPERATO E SERIGRAFATO, SONO COIBENTATI E LA REFRIGERAZIONE È VENTILATA.

THE CABINETS ARE PERFECT FOR KEEPING BOTH BEVERAGES AND FOOD. THESE CABINETS ARE IDEAL FOR STORING CURED MEATS, DELICATESSEN GOODS AND ALSO CONFECTIONERY PRODUCTS. THE TEMPERED AND SILK-SCREEN PRINTED GLASS DOORS ARE INSULATED AND REFRIGERATION IS VENTILATED.



PASTICCERIA  
CONFECTIONERY



BIBITE  
BEVERAGES



GASTRONOMIA  
FREDDA  
DELICATESSEN FOODS





WALLBOX

STILTEK



LA SCENOGRAFIA È UN'ARTE  
CHE UTILIZZA ANCHE LA LUCE.  
QUANDO È BELLA E MIRATA,  
COME QUI, ILLUMINA, ESALTA,  
EVIDENZIA.

SET DESIGN IS AN ART WHICH ALSO USES LIGHT.  
WHEN IT IS ATTRACTIVE AND CAREFULLY  
CHOSEN, AS HERE, IT BRIGHTENS, ENHANCES  
AND HIGHLIGHTS ANY SPACE.

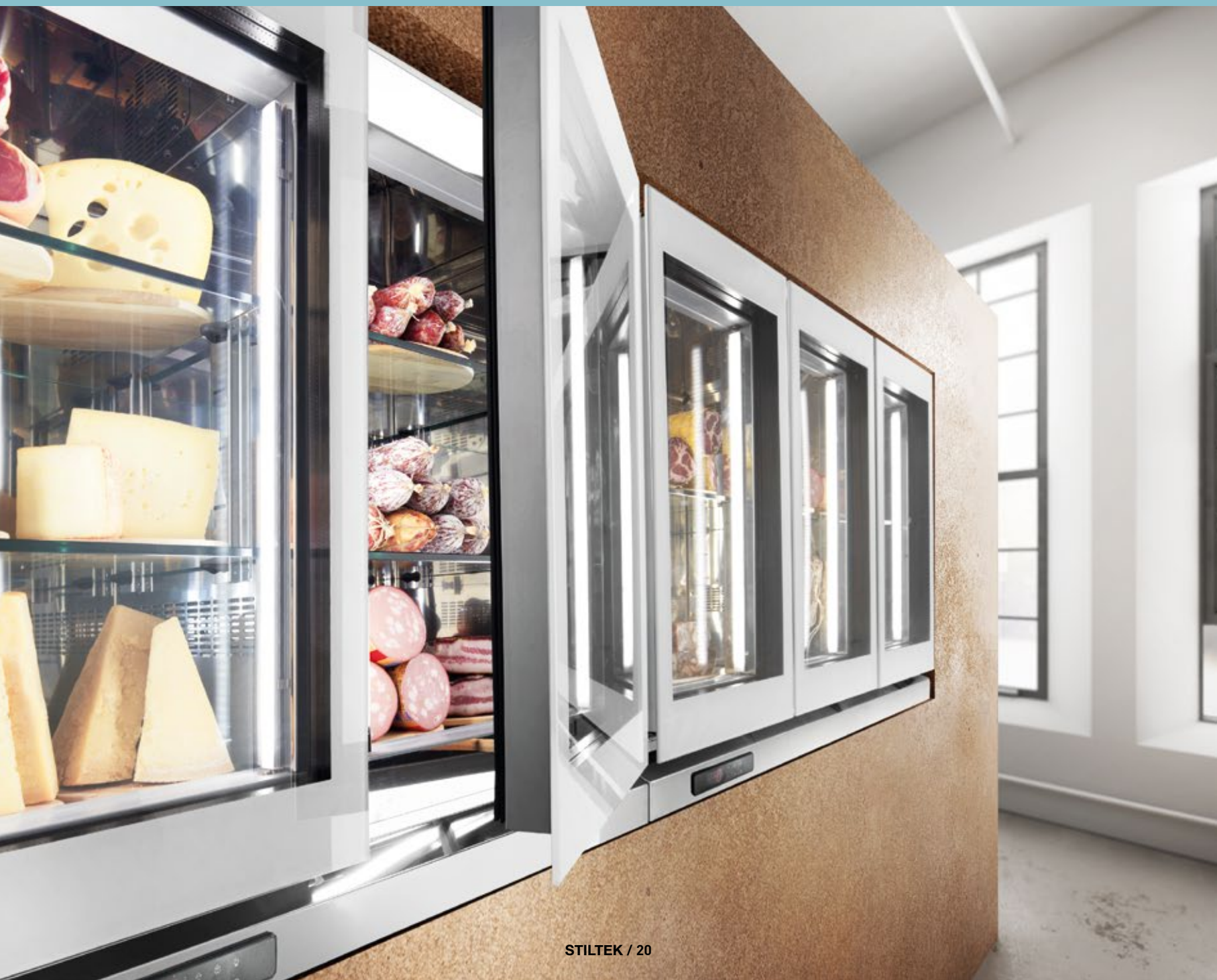



## WALLBOX BIANCO/INOX WHITE/STAINLESS STEEL



**IT\_** Mobile pensile refrigerato per alimenti e bevande con impianto refrigerante ventilato a valvola termostatica, struttura in acciaio rivestito per alimenti e poliuretano iniettato isolante alla densità di 38/40 kg/mc, fondo interno con bordi raggiati e scarico condensa, sportelli in vetrocamera, illuminazione con plafoniere a LED, mensola intermedia in vetro temperato regolabile in altezza, griglie di fondo in acciaio inox, quadro di comando elettronico programmabile, fissaggio a parete con apposita staffa.  
Temperatura di esercizio +2°+7°C

**EN\_** Refrigerated cabinet for food and beverage products with a thermostatic valve ventilated refrigeration system, coated steel structure for foods and 38/40 kg/m<sup>3</sup> injected polyurethane insulation, interior bottom with smooth edges and condensation plughole, double-glazed glass doors, LED ceiling lighting, tempered glass intermediate shelf adjustable in height, stainless steel bottom grills, programmable electronic control panel, wall-mounted with special brackets.  
Operating temperature +2°+7°C

### COLORI STRUTTURA: STRUCTURE COLOURS:

-  sportello bianco  
white door
-  esterno/interno  
inox lucido  
exterior/interior  
shiny stainless steel

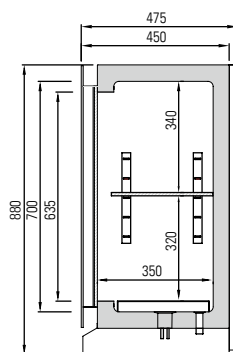

capacità pensile LT 196  
cabinet capacity 196 litres

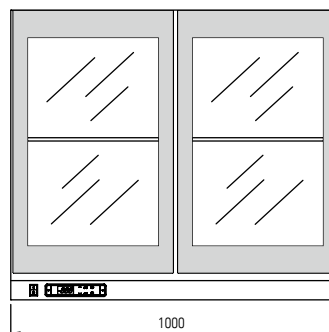

capacità pensile LT 318  
cabinet capacity 318 litres

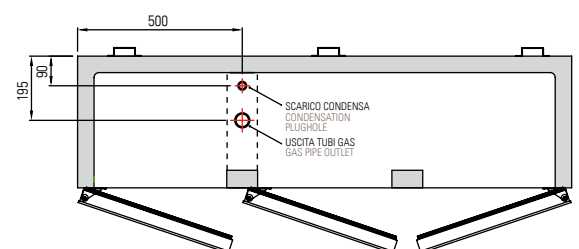
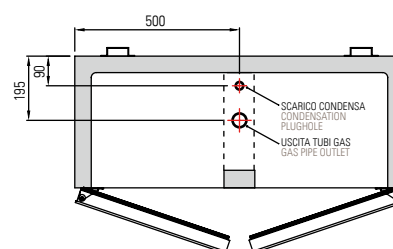
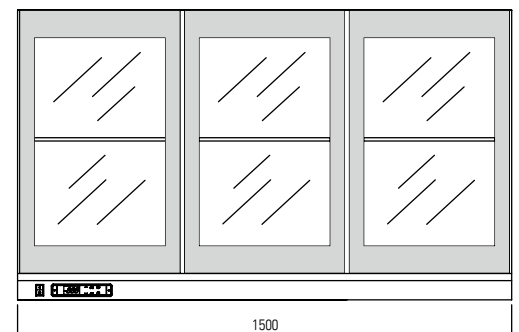

# WALLBOX

I PENSILI REFRIGERATI WALLBOX CONSENTONO UN RAZIONALE UTILIZZO DELLO SPAZIO. I PRODOTTI SONO BEN IN VISTA GRAZIE A SPORTELLI IN VETRO TEMPERATO E SERIGRAFATO E ALL'ILLUMINAZIONE A LED POTENZIATO. LO SPAZIO INTERNO SI PUÒ PERSONALIZZARE GRAZIE ALLE ALTEZZE REGOLABILI DELLE MENSOLE. SPLENDENTE IL RIVESTIMENTO IN ACCIAIO INOX LUCIDO E RAFFINATA LA VERSIONE IN ACCIAIO COLOR NERO.



THE WALLBOX REFRIGERATED CABINETS ALLOW RATIONAL USE OF SPACE. THE PRODUCTS ARE CLEARLY VISIBLE, THANKS TO THE TEMPERED AND SILK-SCREEN PRINTED GLASS DOORS AND THE ENHANCED LED LIGHTING. THE INTERNAL SPACE MAY BE CUSTOMISED THANKS TO THE ADJUSTABLE HEIGHT OF THE SHELVES. THERE IS A SPLENDID SHINY STAINLESS STEEL COATING OR REFINED BLACK STEEL VERSION.

## OPTIONAL

**FRIGOCONNECT** IOT  
INDUSTRY 4.0



TUTTE LE VETRINE ED I BANCHI REFRIGERATI FRIGOMECCANICA, POSSONO ESSERE MONITORATI E COMANDATI DA REMOTO GRAZIE ALL'APP 4.0 "FRIGOCONNECT": CON SERVIZIO DI MESSAGGERIA "PUSH" ED INVIO DEI DATI DI FUNZIONAMENTO, "FRIGOCONNECT" PERMETTE DI GESTIRE LE TEMPERATURE CRITICHE (HACCP) IN AUTOMATICO, UN SISTEMA SMART CHE OTTIMIZZA LA CONSERVAZIONE E LA QUALITÀ DEI PRODOTTI.

ALL FRIGOMECCANICA REFRIGERATED DISPLAY CASES AND COUNTERS CAN BE MONITORED AND CONTROLLED REMOTELY VIA THE 4.0 FRIGOCONNECT APP: FEATURING PUSH NOTIFICATIONS AND OPERATING DATA TRANSMISSION, FRIGOCONNECT ALLOWS FOR AUTOMATIC MANAGEMENT OF CRITICAL TEMPERATURES (HACCP), A SMART SYSTEM THAT OPTIMIZES PRODUCT PRESERVATION AND QUALITY.

PENSILE MOD. CABINET MOD.	LUNGHEZZA LENGTH	VOLUME INTERNO LT INTERIOR VOLUME L.	PESO A VUOTO KG WEIGHT WHEN EMPTY	PESO A PIENO KG WEIGHT WHEN FULL	PORTATA MURO KG/MT WALL-BEARING STRUC
100 U.C.R.	cm 100	196	100	296	300
150 U.C.R.	cm 150	318	130	448	300
100 U.C.I.	cm 142,5	196	135	331	335
150 U.C.I.	cm 192,5	318	165	483	335



U.C.R. unità condensatrice remota / remote condensing unit  
U.C.I. unità condensatrice incorporata / built-in condensing unit

VARIANTI COLORI  
STRUTTURA E SPORTELLI  
AVAILABLE COLOURS  
STRUCTURE AND DOORS

SPORTELLI IN VETRO / GLASS DOORS



MATERIALE INTERNO/ESTERNO  
INTERNAL/EXTERNAL MATERIAL



PIANI REGOLABILI IN ALTEZZA  
SHELVES ADJUSTABLE IN HEIGHT

Versione con unità condensatrice incorporata  
Version with built-in condensing unit



Wallbox è disponibile con unità condensatrice incorporata o remota per distanze fino a 10 metri e oltre. Viene fornito con tubo di scarico per l'acqua di condensa da collegare alla rete. Può essere dotato, a richiesta, di un sistema automatico di smaltimento condensa con resistenza elettrica.

Wallbox is available with a built-in or remote condensing unit for distances up to 10 meters and beyond. It is supplied with a condensation water outlet pipe to be connected to the mains. An automatic condensation removal system with an electrical resistance is also available on request.

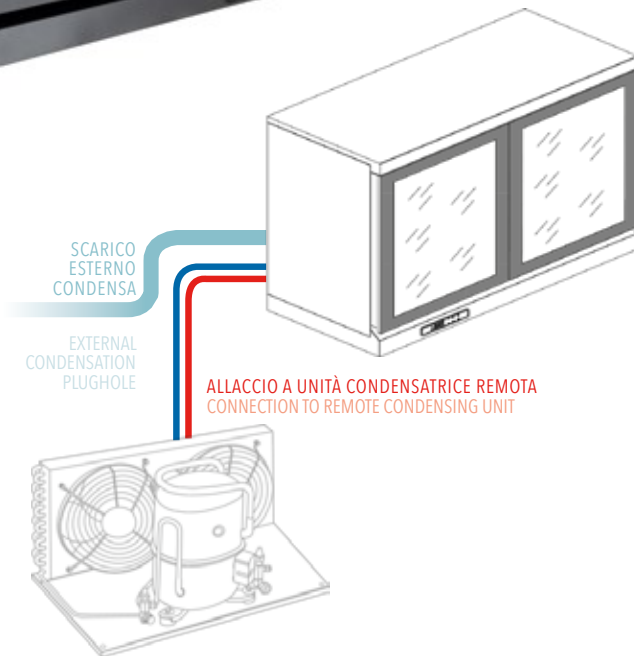

QUADRO COMANDI ELETTRONICO PROGRAMMABILE  
PROGRAMMABLE ELECTRONIC CONTROL PROGRAM



RIVESTIMENTO INTERNO IN ACCIAIO INOX LUCIDO  
O ACCIAIO COLORE NERO PER ALIMENTI  
SHINY OR BLACK STAINLESS STEEL INTERNAL  
COATING FOR FOODS



ILLUMINAZIONE INTERNA A LED POTENZIATO  
ENHANCED LED INTERIOR LIGHTING



PORTE IN VETRO TEMPERATO E SERIGRAFATO  
NEI COLORI BIANCO O NERO  
BLACK OR WHITE TEMPERED AND SILK-SCREEN  
PRINTED DOORS





# ICEBOX

ICEBOX "METTE IN LUCE".  
CONTIENE ED ESPONE AL MEGLIO ALIMENTI  
SU GHIACCIO. EVIDENZIA LA QUALITÀ  
DEL PRODOTTO, LO RENDE APPETIBILE E ATTIRA  
L'ATTENZIONE. ELEMENTO D'ARREDO CON  
ILLUMINAZIONE IMPORTANTE E SCENOGRAFICA.

"VISIBLE" ICEBOX  
CONTAINS AND DISPLAYS FOOD ON ICE  
HIGHLIGHTS THE QUALITY OF THE PRODUCT,  
GIVES IT AN APPETISING LOOK AND ATTRACTS  
ATTENTION DÉCOR ELEMENT WITH  
ATTRACTIVE AND PICTURESQUE LIGHTING





ICEBOX

STILTEK

# ICEBOX



IL MEGLIO DELLA TECNOLOGIA, L'ESSENZIALITÀ DEL DESIGN E UNA QUALITÀ INCONFONDIBILE PER DARE RISPOSTE CONCRETE A ESIGENZE DI FUNZIONALITÀ. ICEBOX NELLE VERSIONI LINE E COMPACT È LA RISPOSTA PERFETTA AD OGNI ESIGENZA DI ESPOSIZIONE CONIUGANDO LA BELLEZZA DELL'ARREDO, PERCHÉ DIAMO ECCEZIONALE VALORE AI CLIENTI E AI PROFESSIONISTI CHE CI SCELGONO.

THE BEST OF TECHNOLOGY, ESSENTIAL DESIGN, AND UNMISTAKABLE QUALITY TO PROVIDE CONCRETE ANSWERS TO FUNCTIONAL NEEDS. ICEBOX, IN THE LINE AND COMPACT VERSIONS, IS THE PERFECT SOLUTION FOR EVERY DISPLAY REQUIREMENT, COMBINING THE BEAUTY OF FURNISHING, BECAUSE WE GIVE EXCEPTIONAL VALUE TO THE CUSTOMERS AND PROFESSIONALS WHO CHOOSE US.



**OPTIONAL**  
 IMPIANTO  
 REFRIGERANTE  
 AFFOGATO  
 CON MOTORE  
 COLLEGATO O  
 REMOTO

**OPTIONAL**  
 SUNKEN  
 REFRIGERATING UNIT  
 WITH CONNECTED  
 OR REMOTE MOTOR

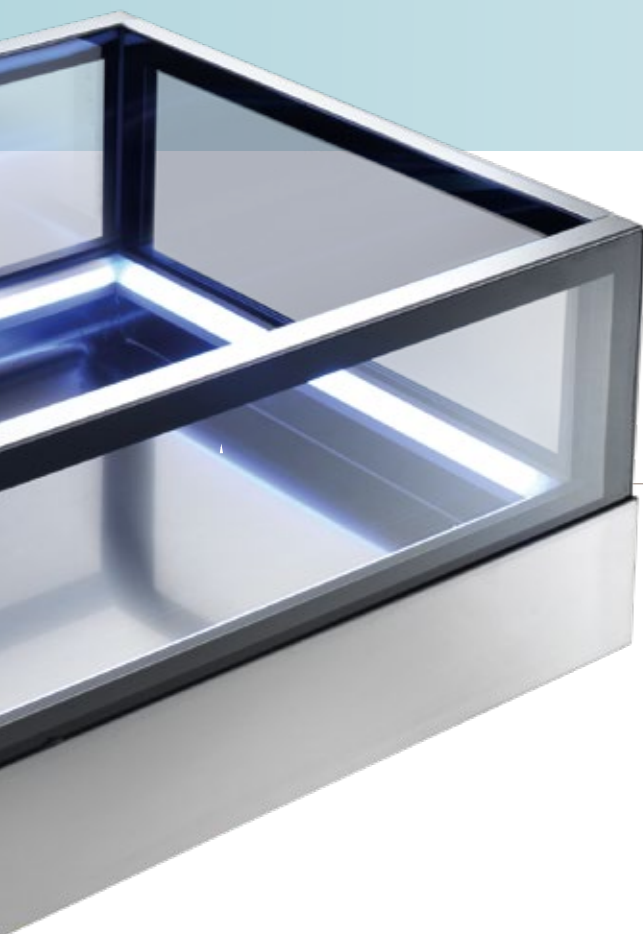
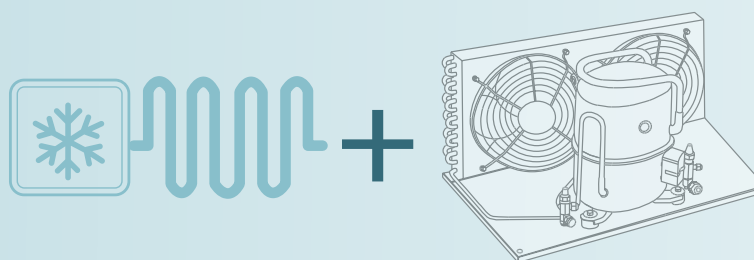

**IT\_** Fondo in monoscocca realizzato in acciaio inox Aisi 304 con scarico, pareti vetrocamera con bordi in alluminio anodizzato, illuminazione con LED ad alta luminosità stagno, con alimentatore a bassa tensione esterno.  
 Optional: impianto refrigerante con serpentina in rame affogata nel fondo.

**EN\_** Monocoque Aisi 304 stainless steel bottom with plughole, double-glazed glass walls with anodised aluminium edges, watertight high-luminosity LED lighting, with external low-voltage power supply.  
 Optional: refrigerating unit with sunken copper coil on the bottom.

## ICEBOX LINE

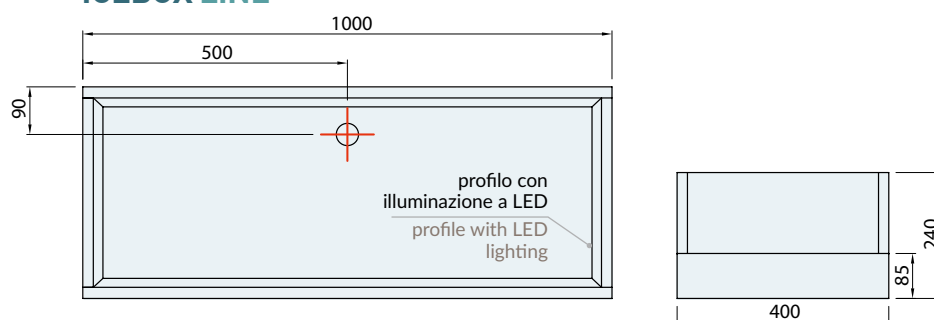

## ICEBOX COMPACT

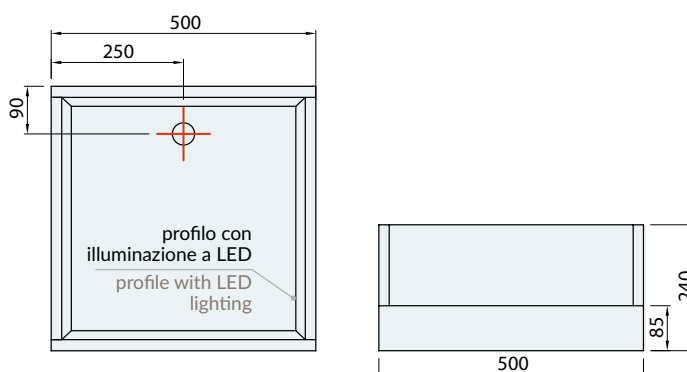





ICEBOX

STILTEK



# ICEBOX

STILTEK



ICEBOX IN VERSIONE LINE  
O COMPACT È FACILMENTE  
ABBINABILE AI MODULI  
WALLBOX ED A QUALUNQUE  
BANCO REFRIGERATO E  
NEUTRO DELLA GAMMA  
STILTEK.

Icebox in Line or Compact  
version is easily combinable with  
Wallbox modules and with any  
refrigerated and ambient counter  
in the Stiltek range.









LA WORKSTATION COCKTAIL, OLTRE ALLA VERSIONE STANDARD, PUÒ ESSERE PERSONALIZZATA SU RICHIESTA IN BASE ALLE ESIGENZE DEL BARMAN E DEL LOCALE IN CUI VERRÀ INSTALLATA, SIA CON L'AGGIUNTA DI COMPONENTI TECNICI, COME CASSETTI REFRIGERATI, CASSETTI PER RIFIUTI, PIANI IN QUARZO E VASCHETTE SUPPLEMENTARI, SIA CON ELEMENTI ESTETICI IN CERAMICA, LEGNO O METALLO DECORATO.

THE COCKTAIL WORKSTATION, IN ADDITION TO THE STANDARD VERSION, CAN BE CUSTOMIZED UPON REQUEST ACCORDING TO THE NEEDS OF THE BARTENDER AND THE VENUE WHERE IT WILL BE INSTALLED, BOTH WITH THE ADDITION OF TECHNICAL COMPONENTS—SUCH AS REFRIGERATED DRAWERS, WASTE DRAWERS, QUARTZ TOPS, AND EXTRA CONTAINERS—AND WITH AESTHETIC ELEMENTS IN CERAMIC, WOOD, OR DECORATED METAL.



# WORKSTATION COCKTAIL

STILTEK



# WORKSTATION COCKTAIL

STILTEK

**IT\_** Icebox e workstation cocktail sono realizzate con materiali robusti e di prima qualità; per questo garantiscono elevate prestazioni e resistenza nel tempo, oltre a offrire un look all'avanguardia.

**EN\_** Icebox and cocktail workstations are made with robust, premium-quality materials; for this reason, they guarantee high performance and long-lasting durability, while also offering a cutting-edge look.



# workstation cocktail

VIA LIBERA ALLA FANTASIA. CONFIGURABILE SECONDO NECESSITÀ E GUSTO INDIVIDUALE, WORKSTATION È UN'INESAURIBILE FONTE DI SUGGERIMENTI. TASCHE, BINARI, VASCHETTE IN UNA CORNICE D'ACCIAIO INOX. CON L'ESPERIENZA OGNUNO TROVA LA PROPRIA CONFIGURAZIONE IDEALE, MA ALCUNE REGOLE SONO FISSE. IN PRIMO PIANO I LIQUORI DI UTILIZZO PRINCIPALE, LA FRUTTA PER GUARNIRE, IL TAGLIERE, COLTELLINI E ALTRI UTENSILI INDISPENSABILI.

LET YOUR IMAGINATION RUN WILD CONFIGURABLE TO INDIVIDUAL NEEDS AND TASTES, WORKSTATION IS AN ENDLESS SOURCE OF IDEAS. POCKETS, RACKS AND TUBS IN A STAINLESS STEEL FRAME EVERYONE CAN CHOOSE THEIR IDEAL CONFIGURATION BASED ON EXPERIENCE, BUT CERTAIN RULES ARE FIXED. THE MOST FREQUENTLY USED SPIRITS, THE FRUIT FOR GARNISHING, THE CUTTING BOARD, KNIVES AND OTHER UTENSILS SHOULD BE WITHIN THE EASIEST REACH.

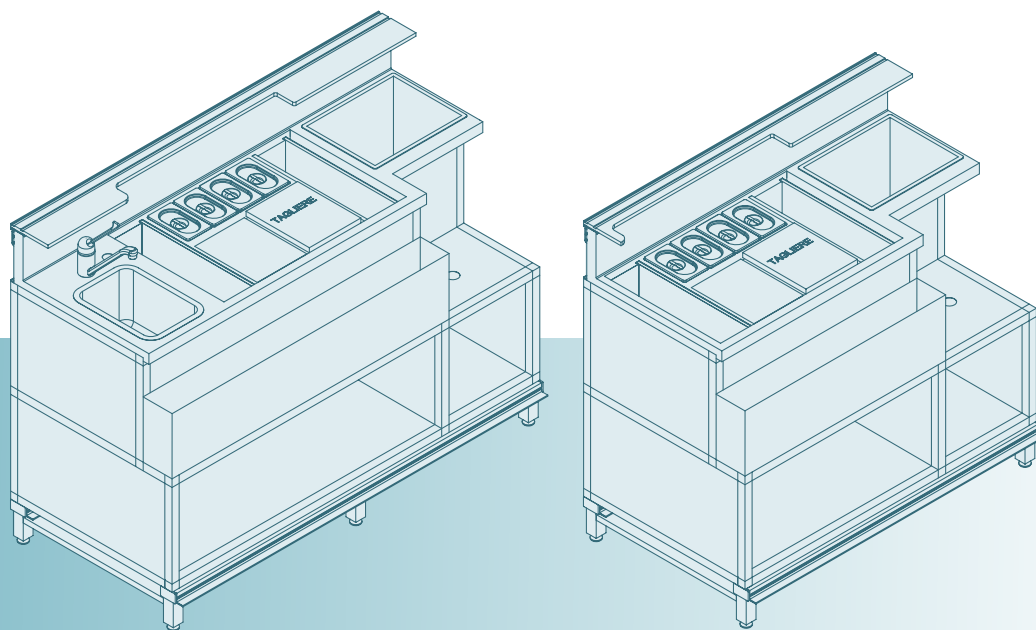

**IT\_** Speed rack, in acciaio inox, posto proprio davanti al barman, formato da piani e tasche per bottiglie e binari. Rivolto al bartender, gli offre il massimo della facilità e rapidità di manovra. Attrezzabile per ogni personalizzazione.

**EN\_** Stainless steel speed rack, placed in front of the barman, formed of work surfaces, pockets for bottles and racks. Designed to allow the bartender to move around easily and quickly. Customisable with other equipment.





# workstation cocktail

I DISTILLATI PIÙ COMUNI PER I COCKTAIL, LE VASCHETTE PER LA FRUTTA E I BINARI PER I SUCCHI SONO QUI DISPOSTI IN MODO DA ESSERE RAGGIUNTI SEMPLICEMENTE ALLUNGANDO UNA MANO. AL CENTRO, IL BARMAN SI MUOVE RAPIDO NEL SUO MONDO COLORATO.

THE MOST COMMON COCKTAIL DISTILLATES, FRUIT BOWLS AND THE JUICE RACKS ARE ARRANGED HERE TO BE EASILY WITHIN ARM'S REACH. THE BARMAN MOVES QUICKLY AT THE CENTRE OF HIS COLOURFUL WORLD.



DUE MINUTI AL MASSIMO PER UN COCKTAIL... ATTREZZATO NEL MODO CORRETTO, IL BANCONE È IL MIGLIORE ALLEATO DEL BARMAN E GLI CONSENTE DI VELOCIZZARE I TEMPI PER ACCELERARE AL MASSIMO IL SERVIZIO.

A MAXIMUM TWO MINUTES TO MAKE A COCKTAIL... IF EQUIPPED PROPERLY, THE COUNTER IS THE BARMAN'S CLOSEST ALLY AND ENSURES MORE RAPID SERVICE



# workstation cocktail



IL GHIACCIO NON DEVE MAI MANCARE. FONDAMENTALE NEI DRINK E NEI COCKTAIL, COSÌ COME OGNI ELEMENTO DEL BANCO.

ICE MUST ALWAYS BE AVAILABLE IT IS AN ESSENTIAL PART OF DRINKS AND COCKTAILS, LIKE ALL OTHER ELEMENTS OF THE COUNTER.









**IT\_** Struttura in tubolare di alluminio anodizzato lucido ed acciaio inox. Il piano è dotato di lavello con miscelatore (solo sul modulo da 150 cm.) Vasca centrale coibentata per ghiaccio dotata di scarico, n.4 vaschette inox GN1/9, tagliere in polietilene, speed rack per bottiglie, vasca con griglia per stoccaggio bicchieri, appoggio ribassato per mixer/tritaghiaccio, vani a giorno con fondo asportabile.

**EN\_** Shiny tubular anodised aluminium and stainless steel structure. The work surface has a sink with mixer tap (only on 150 cm. module) Insulated central ice-box with plughole, 4 GN1/9 stainless steel tubs, polyethylene cutting board, speed rack for bottles, tub with grill for storing glasses, lowered surface for mixer//ice crusher, open compartments with removable bottom.

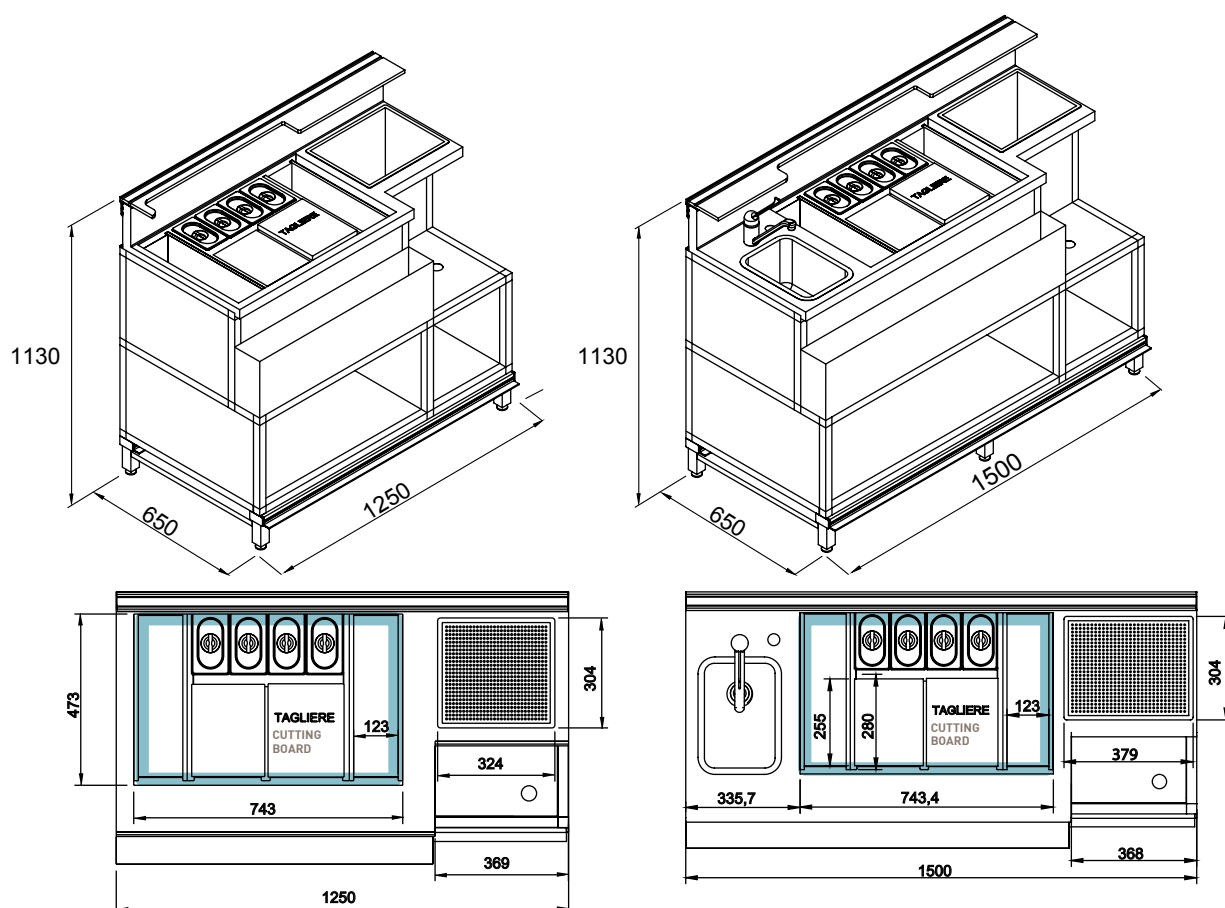

**VASCA COIBENTATA**  
INSULATED TUB



**Stiltek si riserva il diritto di apportare modifiche ai prodotti illustrati in questo catalogo in qualunque momento senza l'obbligo di preavviso.**

Stiltek reserves the right to make changes to the products shown in this catalogue at any time without notice.

Stiltek se réserve le droit d'apporter à tout moment des modifications aux produits illustrés dans cette brochure, sans aucune obligation de préavis.

Stiltek behält sich das Recht vor, jederzeit und ohne Vorankündigung Änderungen an den in diesem Katalog gezeigten Produkten vorzunehmen.

Stiltek se reserva el derecho de aportar modificaciones a los productos presentados en este catálogo en cualquier momento y sin obligación de aviso previo.

---



# STILTEK

Stiltek - divisione di Frigomeccanica S.r.l.  
Via del Progresso, 10  
64023 Mosciano S. Angelo (TE) Italy

Tel. +39 085 80793  
info@stiltek.it

[www.stiltek.it](http://www.stiltek.it)

an **arneg** company